



## **KBHCT09C8S44**

Pico-i, Twist & Lock LED Bulkhead, Built-in 9W LED Tray



## **Product Overview**

Kosnic's Pico-i Integrated LED Bulkhead comes with built-in DoB (driver-on-board) LED modules. The bulkhead is IP44 rated when ceiling mounted and has a simple edge-less vacuum formed polycarbonate cover with high LOR. Altogether the bulkhead offers a simple and elegant solution to lighting in corridors, staircases, thoroughfares and other areas where a practical lighting solution is required.

# Features

Integrated DoB LED modules

Twist and lock fast fit

Class I

IP44 when ceiling mounted

High lumen output

Long life of 40,000h

Instant start

Negligible UV output

Surge protection

# Specifications

KBHCT09C8S44-W40	
Shape / Type	Bulkhead
Materials	Polycarbonate and metal
Power (W)	9
Total Lumens (lm)	730
Input Current (mA)	72
Input Voltage	220-240Vac 50-60Hz
CCT Temperature (k)	4000
CCT Name	Cool White
Rated Life (hrs)	40000
Switch Cycles	50000
CRI	84
Dimmable	No
Power Factor	0.54
IP Rating	IP44
Class Protection	Class I
Warm-up Time (s)	Instant full light
Depth (mm)	98
Diameter (mm)	260
Mercury (mg)	0
LMF at Lifetime	0.75
SDCM of CCT	<6
Photobiological Risk Group	Exempt
Ambient Temperature (°C)	-20 to 40

Barcode 5060063426020

## Packaging

KBHCT09C8S44-W40	
Outer Box Length (mm)	695
Outer Box Width (mm)	495
Outer Box Height (mm)	345
Volume	0.118688625
Box Quantity	10
Outer Box Weight (kg)	11.4

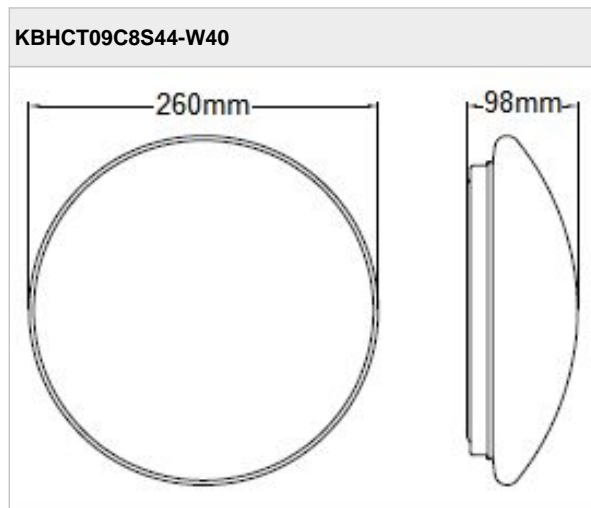

KBHCT09C8S44-W40

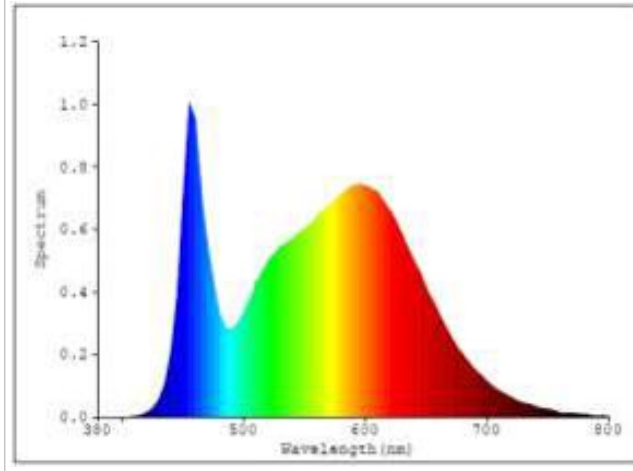

KBHCT09C8S44-W40

This luminaire contains built-in LED lamps.

The lamps cannot be changed in the luminaire.

**Kosnic**

874/2012

Energy efficiency scale: A++, A+, A, B, C, D, F. The scale is marked with a red 'X' over the lower ratings (B, C, D, F). The label is also marked with 'LED' and a European Union flag.

Datasheet generated from <https://www.electrika.com> last updated Friday, April 26, 2019 11:21:34 AM