

EVO ORB

Technical Specification

Product Code: OV9700WH16MW

Description: 16W LED Bulkhead - Microwave Sensor - IP65 - CTA - White

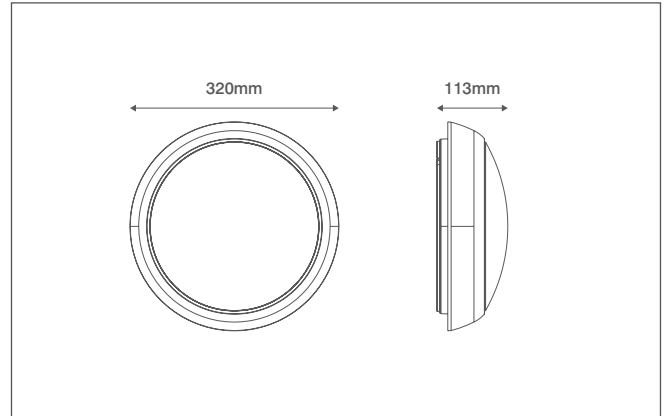

General Information

Dimensions	320mm Diameter x 113mm (D)
Materials	Base & Diffuser: Polycarbonate (UV Stabilised) Gear Tray: Powdercoated Steel LED Array: Aluminium Substrate
Finish	White (RAL 9010)
Product Weight	0.99Kg
Corridor Function	Yes (10% or 25% Output)
Ingress Protection	IP65
Flammability	UL94-V2
Warranty	5 Years

Supply & Power

Input Voltage & Frequency	200-240V~ 50/60Hz
Electrical Safety	Class II (Double Insulated)
LED Wattage	16W
Circuit Wattage	16W
Input Current	120mA
Power Factor	>0.95
Ambient Temperature (Ta)	0°C - +50°C
Critical Temperature	+80°C
LED Driver	Integrated
Termination	3 Pole Push-fit Terminals

Luminaire Output

Colour Temperature	3000K	4000K	6000K
Typical Luminous Flux	1250lm	1500lm	1400lm
Efficacy	78lm/W	93lm/W	87lm/W
Beam Angle	107°	107°	107°
CRI	>80		
LED Lifetime (L70)	30,000 Hours		

Microwave Information

Detection Angle	≤150°
Detection Distance	8 - 14 Metres Diameter
Installation Height	2.5 - 6 Metres
Hold Time (Time Delay)	5 secs / 90 secs / 3 mins / 10mins
Lux Level	15 Lux / Disable
Detection Area	50% or 100%
Dimming Stand-by Period	0 sec / 30 secs / 10 mins / +∞
Stand-by Dimming Level	10% or 25% (Corridor Functions)
HF System	5.8GHz ±75MHz
Master/Slave Facility	Not Available

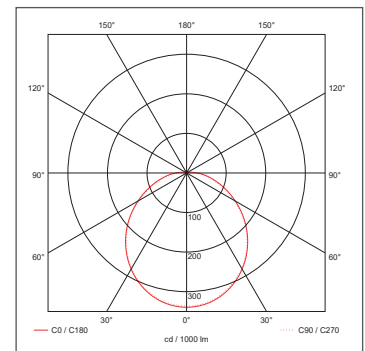

3000K

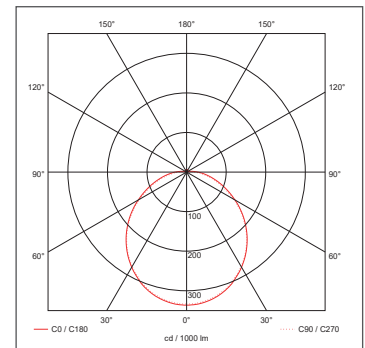

4000K

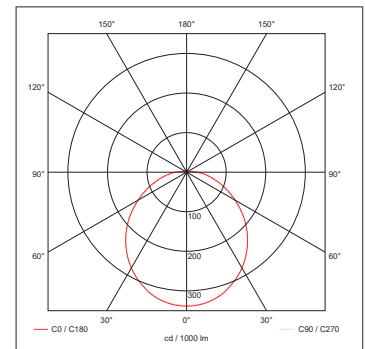

6000K



Ovia Limited, Scolmore House, Mariner, Lichfield Road Industrial Estate, Tamworth, Staffordshire, B79 7UL United Kingdom

T: +44 (0)1827 300640

E: sales@oviaUK.com | W: oviaUK.com